

**FEATURES**

- Heat transfer through ceramic.
- Hard solder joints for high reliability
- Isolated base mounting

**TYPICAL APPLICATIONS**

- DC motor control
- AC motor soft starters
- Temperature control for oven
- Chemical processes and professional light dimming

**TECHNICAL DATA**



DEVICE TYPE	$V_{RRM}$ (V)	$V_{RSM}$ (V)
IRKT55/12, IRKH55/12	1200	1300
IRKT55/16, IRKH55/16	1600	1700
IRKT55/20, IRKH55/20	2000	2100
IRKT55/22, IRKH55/22	2200	2300

SYMBOL	CONDITIONS	VALUES
$I_{TAV}$ $I_{RMS}$	Sin. 180; $T_{case} = 85^{\circ}C$ $T_a = 35^{\circ}C$	50 amp. 130 amp.
$I_{TSM}$ $I^2t$	$T_{vj} = 25^{\circ}C$ ; 10ms $T_{vj} = 25^{\circ}C$	1500 amp. 11000 A <sup>2</sup> S
$I_{RRM} / I_{DRM}$	$T_{vj} = 25^{\circ}C$ $T_{vj} = 125^{\circ}C$	2 mA 15 mA
$V_T$ $V_0$ $R_0$	$T_{vj} = 25^{\circ}C$ ( $I_T = 200$ Amp.); max $T_{vj} = 125^{\circ}C$ $T_{vj} = 125^{\circ}C$	1.65 V 0.9 V 3.5 mΩ
$I_{GT}$ $V_{GT}$ $I_H$ $I_L$	$T_{vj} = 25^{\circ}C$ $T_{vj} = 25^{\circ}C$ $T_{vj} = 25^{\circ}C$ Typical value $T_{vj} = 25^{\circ}C$ Typical value	150 mA 3.0 V 250 mA 600 mA
$R_{th(j-c)}$  $R_{th(c-h)}$ $T_{vj}$ $T_{stg}$	Cont. } Sin. 180 } per thyristor/per module Sin. 120 } Per thyristor/per module	0.57/0.29 °C/W 0.60/0.30 °C/W 0.64/0.32 °C/W 0.20/0.10 °C/W 125 °C (-) 40 to (+) 125 °C
Mounting torque		5 Nm/Per bolt
Weight	Approx.	95 gms
$V_{(isol)}$	Ac 50 Hz rms 1 min	3000 volts
Package Outline		IR-1

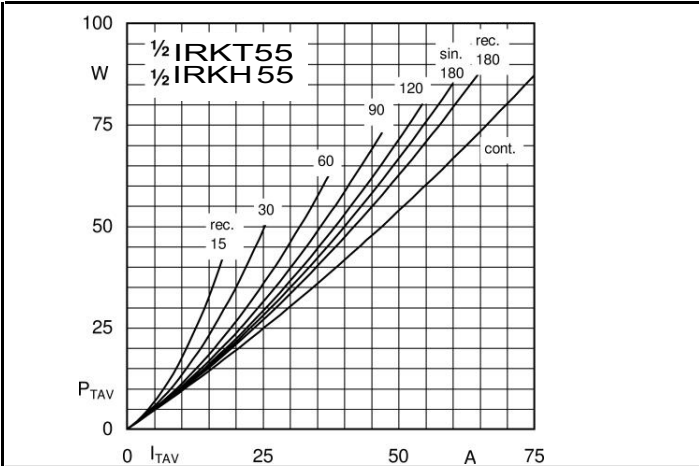

Fig. 1L Power dissipation per thyristor vs. on-state current

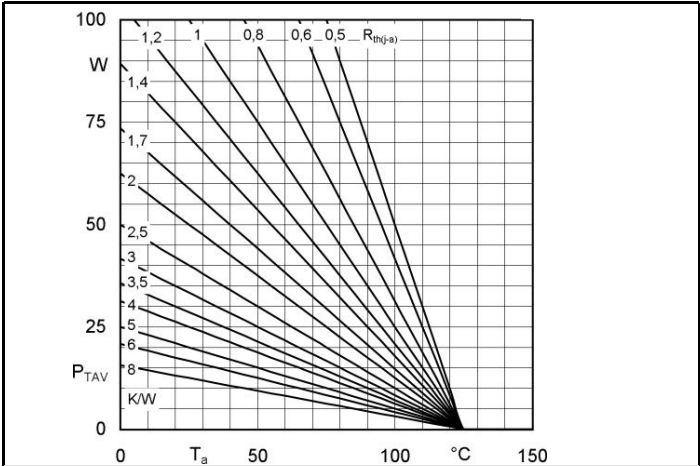

Fig. 1R Power dissipation per thyristor vs. ambient temp.

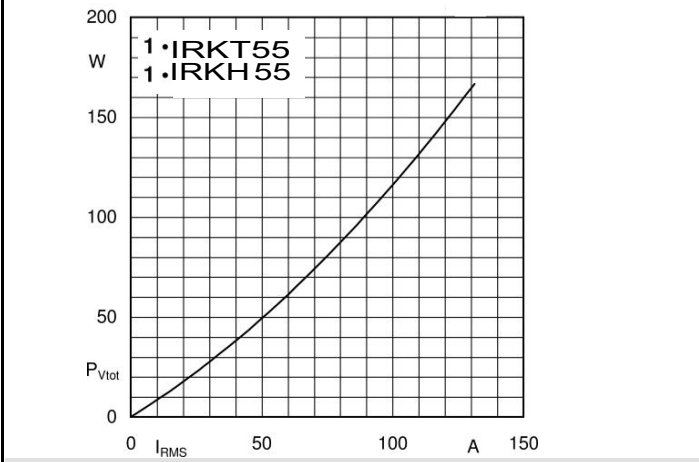

Fig. 2L Power dissipation per module vs. rms current

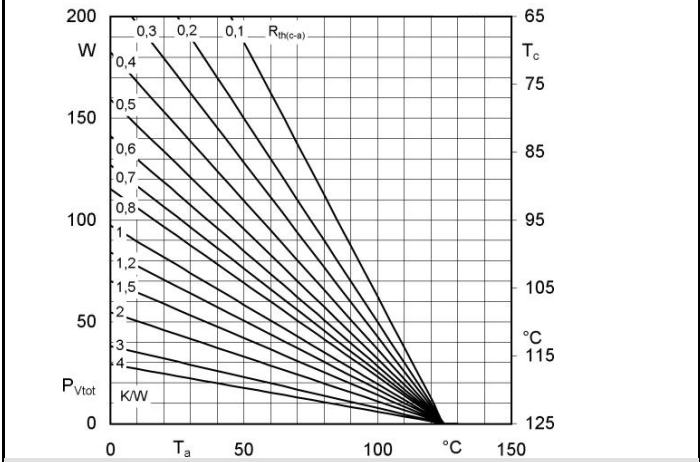

Fig. 2R Power dissipation per module vs. case temp.

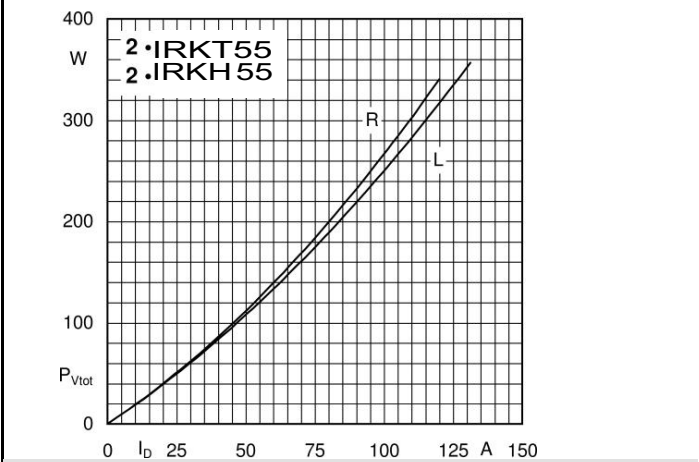

Fig. 3L Power dissipation of two modules vs. direct current

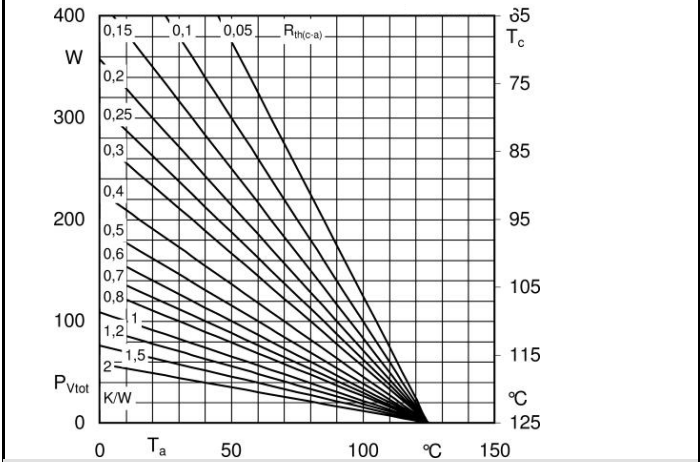

Fig. 3R Power dissipation of two modules vs. case temp.

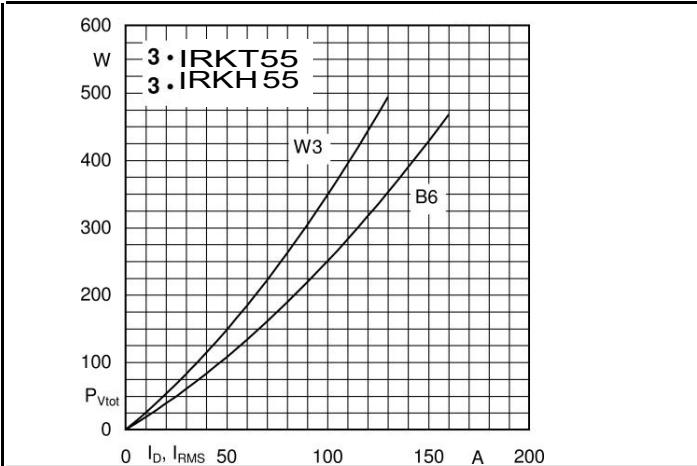

Fig. 4L Power dissipation of three modules vs. direct and rms current

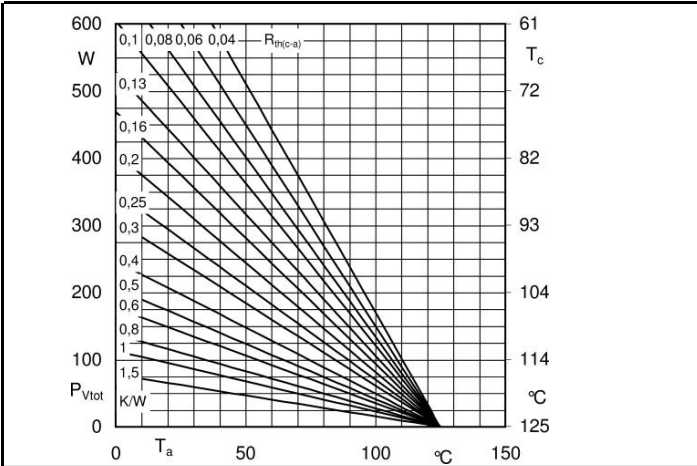

Fig. 4R Power dissipation of three modules vs. case temp.

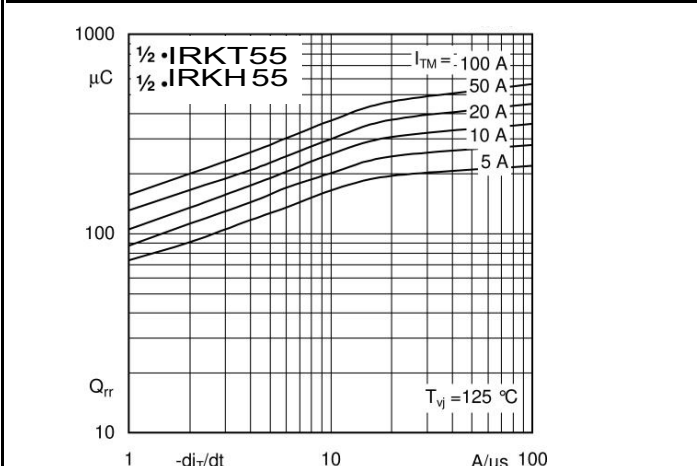

Fig. 5 Recovered charge vs. current decrease

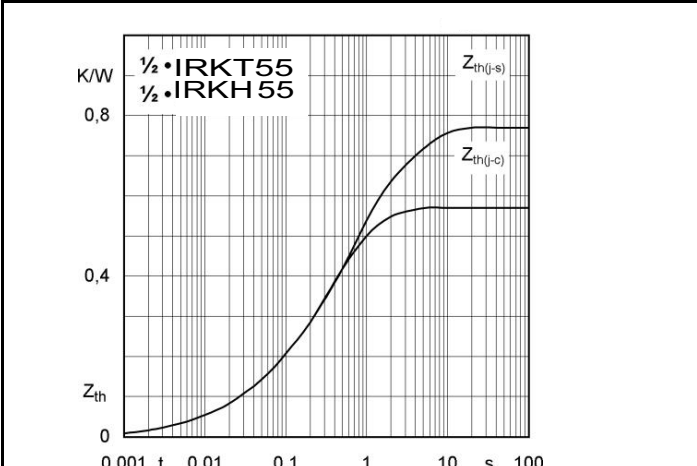

Fig. 6 Transient thermal impedance vs. time

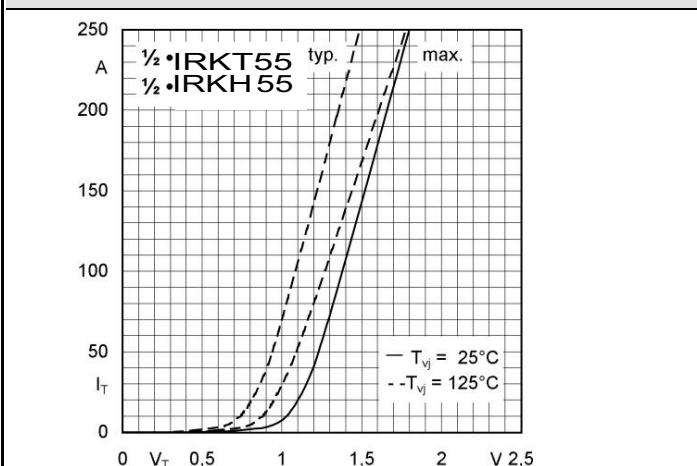

Fig. 7 On-state characteristics

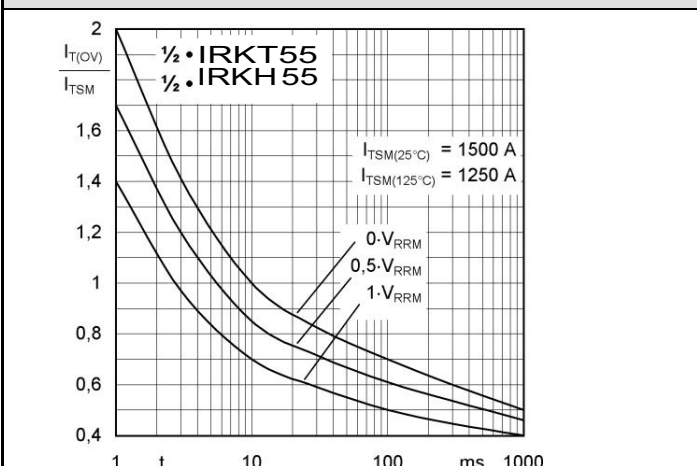

Fig. 8 Surge overload current vs. time

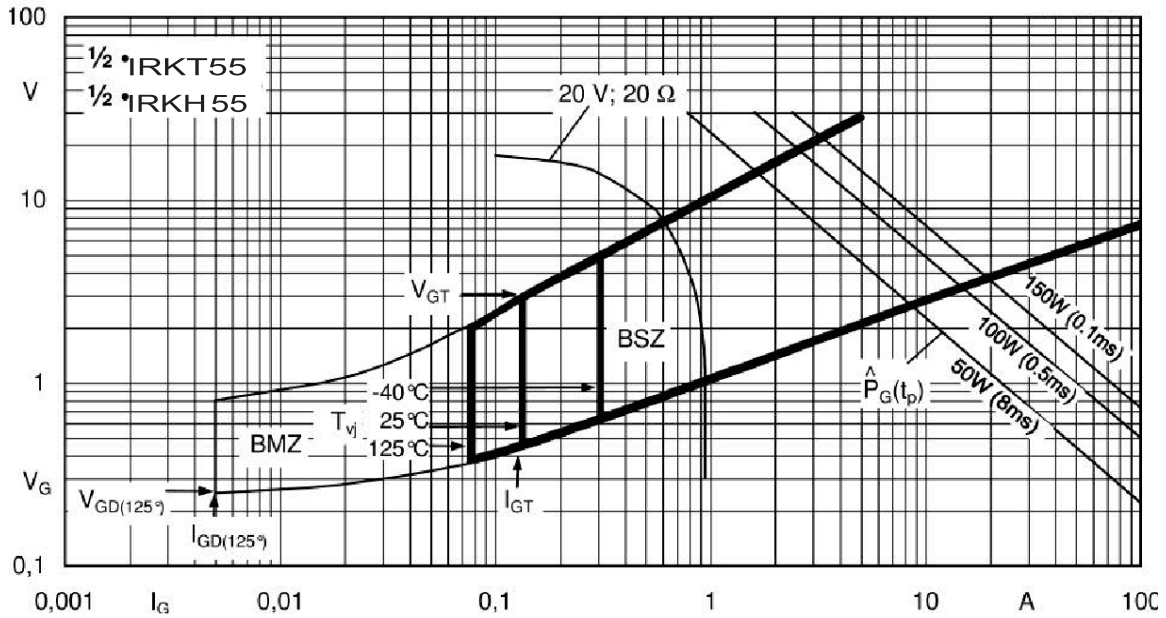
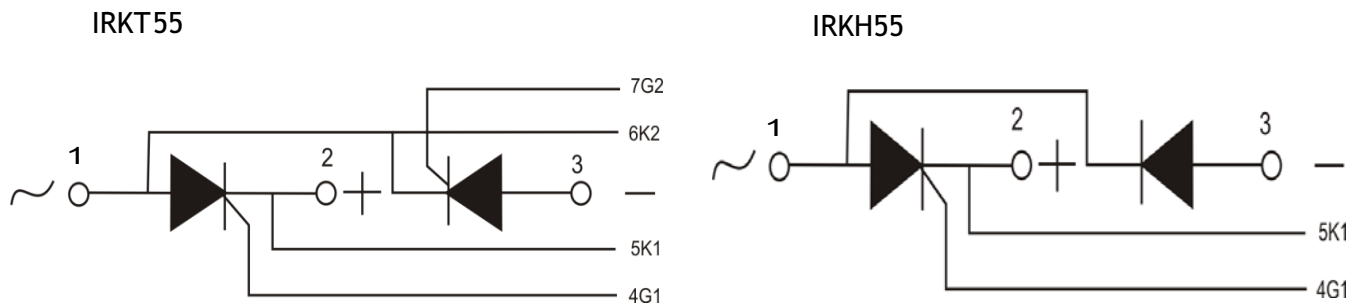
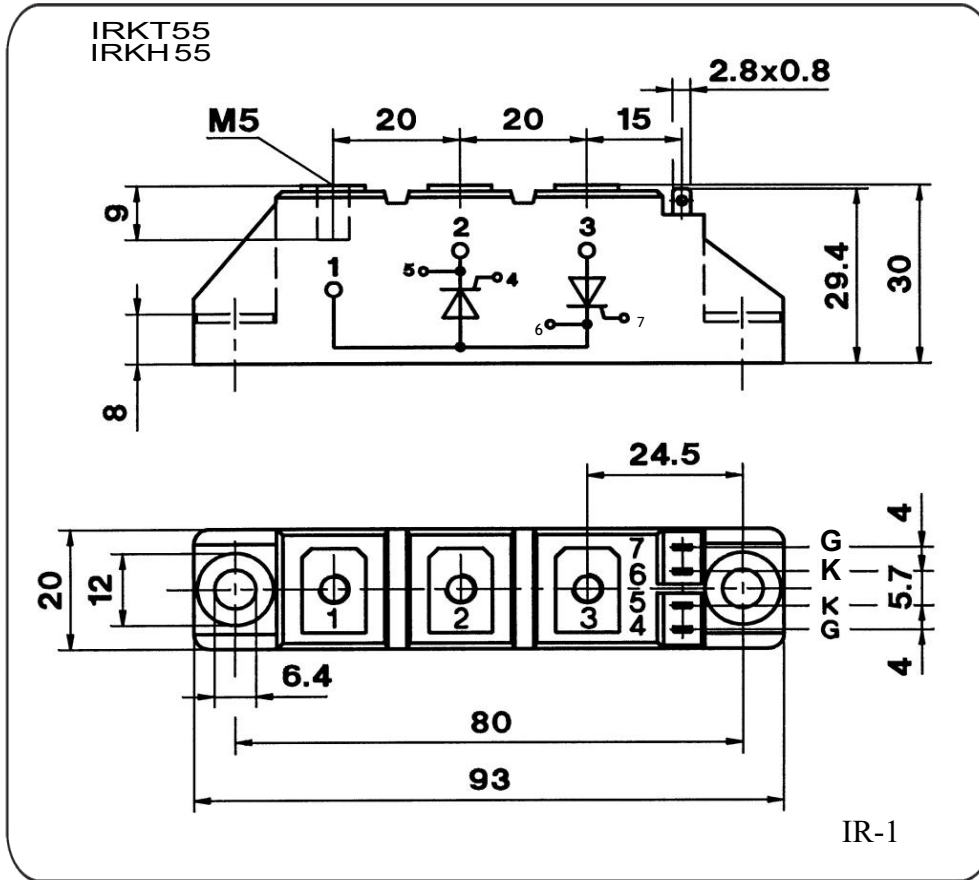

Fig. 9 Gate trigger characteristics

### CIRCUIT DIAGRAM



**PACKAGE OUTLINE**



All dimension are in mm .

**Insel Rectifiers (India) Pvt. Ltd.**

(An ISO 9001:2015, ISO 14001:2015 Certified Company)

Plot No 151, Udyog Kendra, Extn.-II, Ecotech-III, Greater Noida-201306

Toll Free No.: 1800 3070 9989, Fax : 011-27491404

E-mail : [insel@rectifierindia.com](mailto:insel@rectifierindia.com), [sales@rectifierindia.com](mailto:sales@rectifierindia.com)