

FEATURES

- Heat transfer through ceramic.
- Hard solder joints for high reliability
- Isolated base mounting

TYPICAL APPLICATIONS

- Non-controllable rectifiers for AC-AC converters
- Line rectifiers for transistorized AC motor controllers
- Field supply for DC motor

TECHNICAL DATA

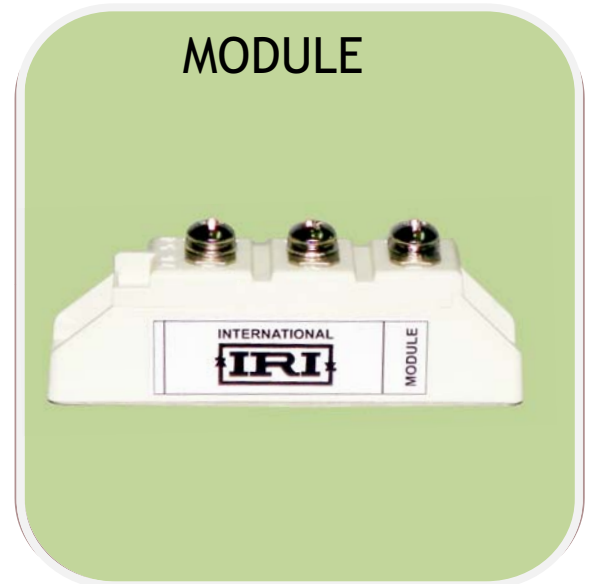

DEVICE TYPE	V _{RRM} (V)	V _{RSM} (V)
IRKD92/12	1200	1300
IRKD92/16	1600	1700
IRKD92/20	2000	2100
IRKD92/22	2200	2300

SYMBOL	CONDITIONS	VALUES
I _{FAV}	Sin. 180; T _{case} = 100°C	100amp.
I _{FSM} I ² t	Tvj=25°C; 10 ms Tvj=25°C	2020 amp. 20.43 KA ² s
I _{RRM}	Tvj=25°C Tvj=125°C	1 mA 5 mA
V _F V ₀ R ₀	Tvj=25°C (I _F =150Amp.); max Tvj=125°C Tvj=125°C	1.45 V 0.79 V 1.78mΩ
R _{th(j-c)} R _{th(c-h)} Tvj Tstg	per module per module	0.35°C/W 0.10 °C/W -40 to +125 °C -40 to +125 °C
Mounting torque		5 Nm/Per bolt
Weight	Approx.	95 gms
V _(isol)	Ac 50 Hz rms 1 min	3000 volts
Package Outline		IR-1

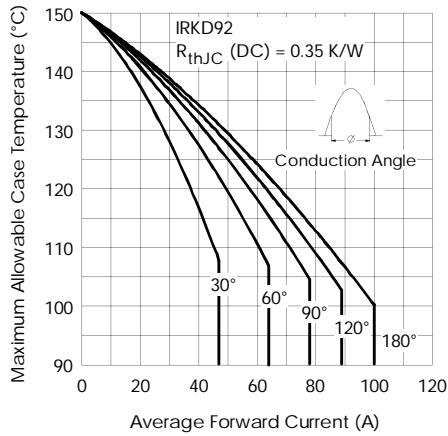

Fig. 1 - Current Ratings Characteristics

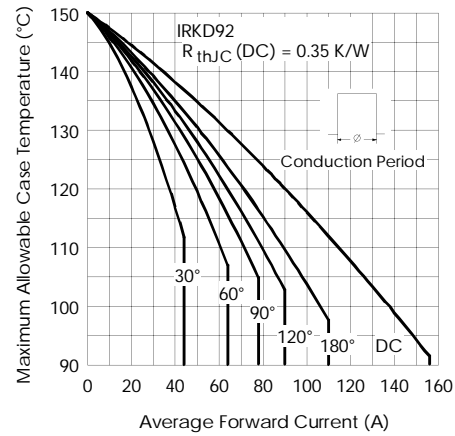

Fig. 2 - Current Ratings Characteristics

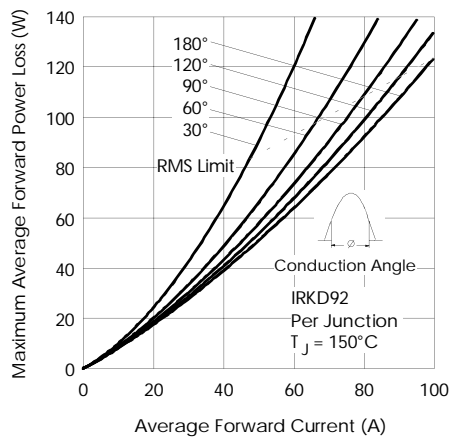

Fig. 3 - Forward Power Loss Characteristics

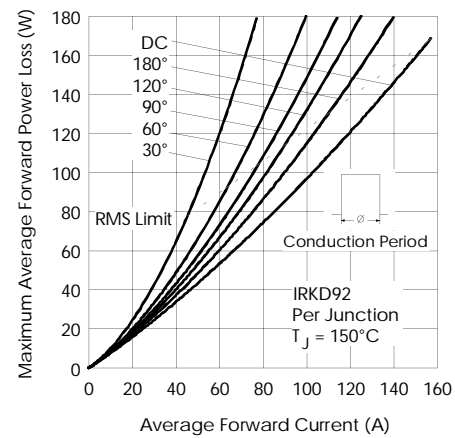

Fig. 4 - Forward Power Loss Characteristics

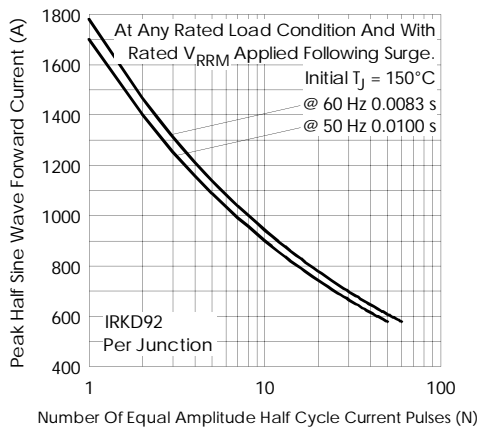

Fig. 5 - Maximum Non-Repetitive Surge Current

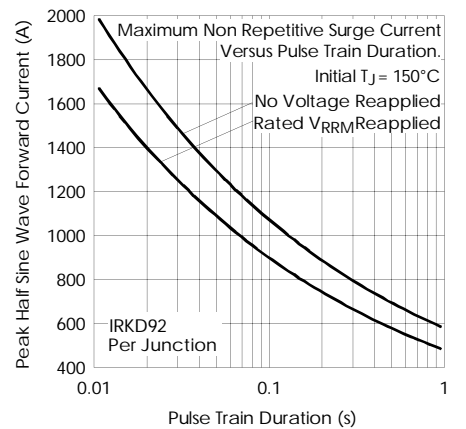

Fig. 6 - Maximum Non-Repetitive Surge Current

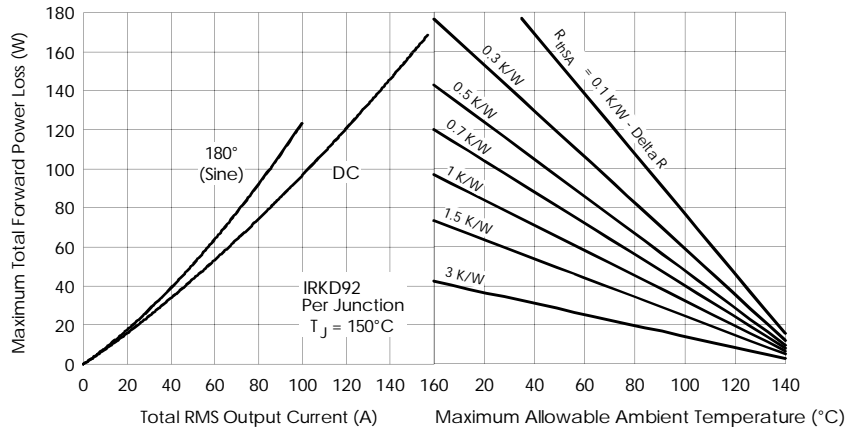

Fig. 7 - Forward Power Loss Characteristics

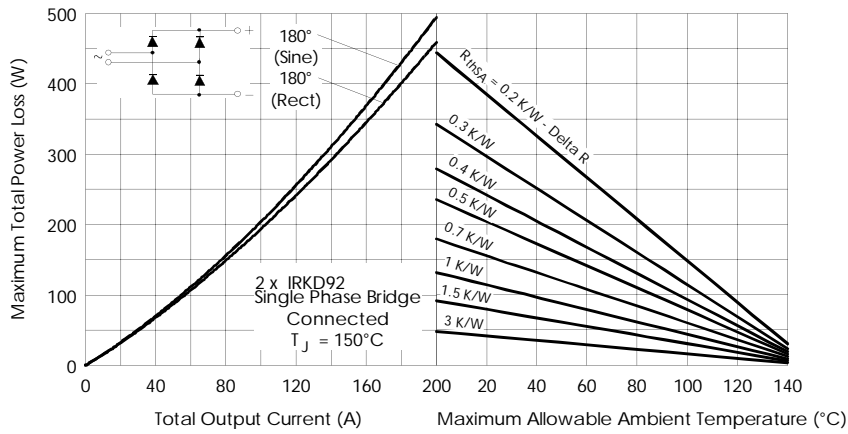

Fig. 8 - Forward Power Loss Characteristics

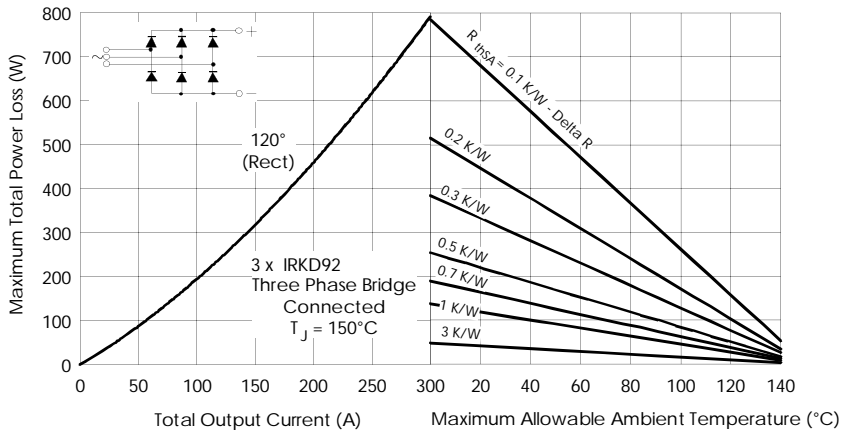

Fig. 9 - Forward Power Loss Characteristics

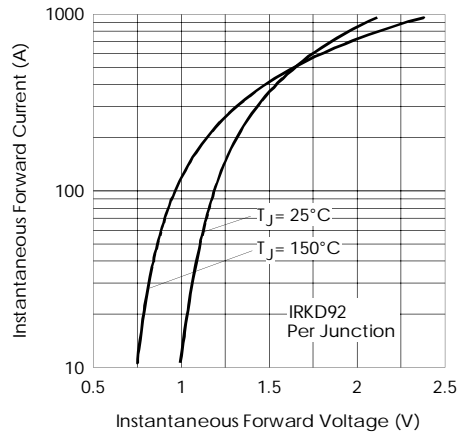

Fig. 10 - Forward Voltage Drop Characteristics

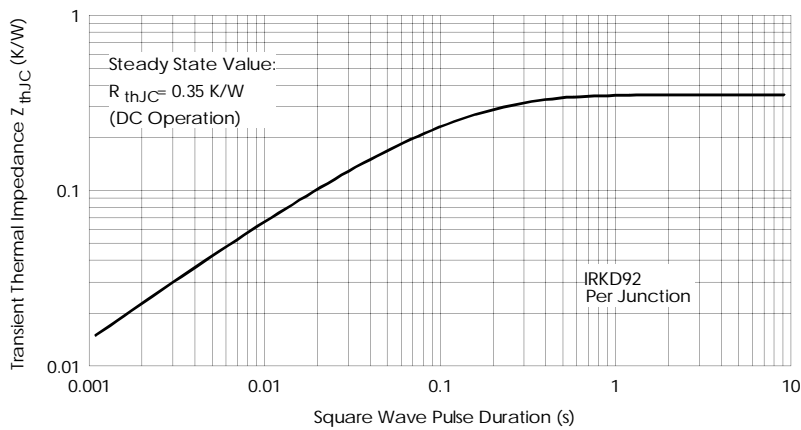
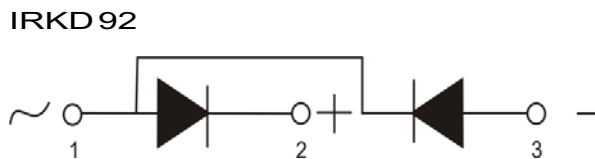

Fig. 11 - Thermal Impedance Z_{thJC} Characteristic

CIRCUIT DIAGRAM



PACKAGE OUTLINE

IRKD92

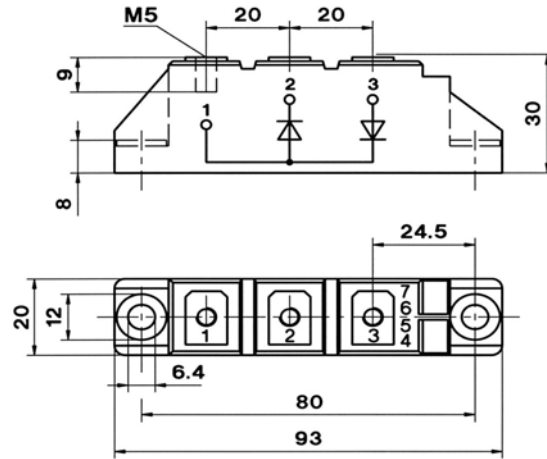

IR- 1

All dimensions are in mm.

Insel Rectifiers (India) Pvt. Ltd.

(An ISO 9001:2015, ISO 14001:2015 Certified Company)

Plot No 151, Udyog Kendra, Extn.-II, Ecotech-III, Greater Noida-201306

Toll Free No.: 1800 3070 9989, Fax : 011-27491404

E-mail : insel@rectifierindia.com, sales@rectifierindia.com