

POWER DIODE

70NC/70RC

FEATURES

- 👉 Available in Normal & Reverse Polarity
- 👉 All Diffused Series
- 👉 Industrial Grade
- 👉 Available in Avalanche Characteristic



DO5

TYPICAL APPLICATIONS

- 👉 Power Supplies
- 👉 Machine Tool Controls
- 👉 Battery chargers
- 👉 Welders

POWER DIODE 70NC/RC



TECHNICAL DATA

DEVICE TYPE	V _{RRM} (V)	V _{RSM} (V)
70NC/RC40	400	500
70NC/RC120	1200	1300
70NC/RC160	1600	1700

SYMBOL	CONDITIONS	VALUES
I _{F(AV)}	Maximum average forward Current T _c = 140 ⁰ C	70A
V _{FM}	Maximum peak forward Voltage drop @ Rated I _{F (Peak)}	1.35 V
I _{FSM}	Maximum peak one cycle (non-rep.) surge current 10 msec	1200 A
I ² t	Max. I ² t rating (non-rep.) for 10 msec	7100 A ² Sec
I _{RRM}	Peak reverse current at T _{vj} = 140 ⁰ C	10 mA
V ₀	T _{vj} =max	0.85 V
R ₀	T _{vj} =max	3.0 mΩ
R _{th(j-c)}	Maximum thermal resistance (Junction to case)	0.45 °C/W
R _{th(c-h)}	Maximum thermal resistance (Case to heat sink)	0.25 °C/W
T _{vj}	Junction temperature	180 °C
T _{stg}	Storage temperature	180 °C
Mounting torque		4 Nm
Weight	Approx.	40 gms
Package Outline		C

POWER DIODE 70NC/RC

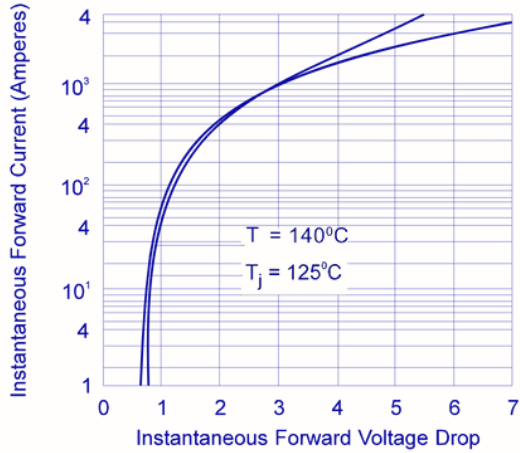

FIG. 1 forward voltage drop vs. forward current

FIG. 2 average forward current vs. case temperature

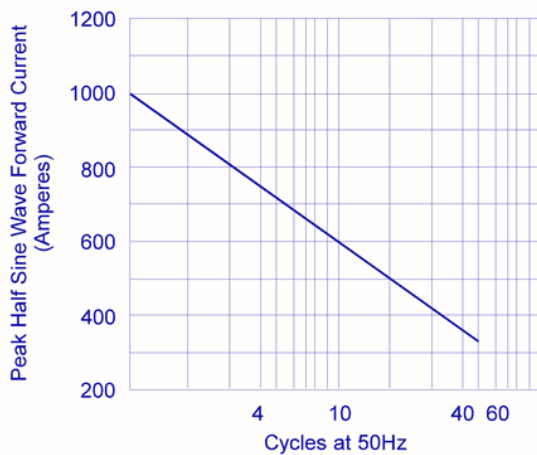
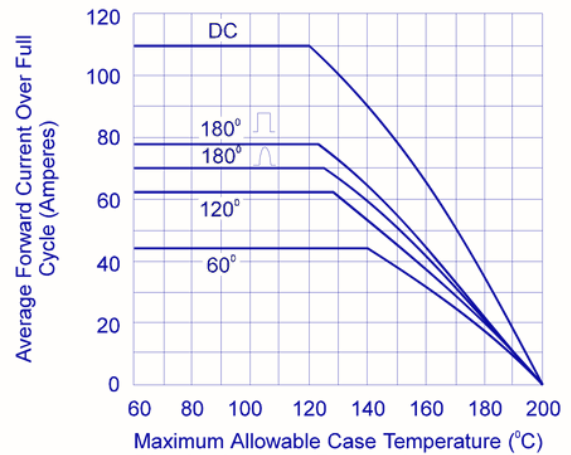

FIG. 3 maximum non recurrent surge current

POWER DIODE 70NC/RC

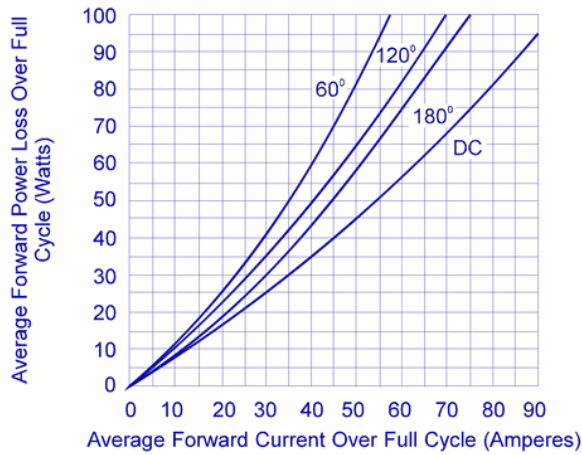

FIG. 4 maximum forward power loss vs. low level forward current

FIG. 5 transient thermal impedance

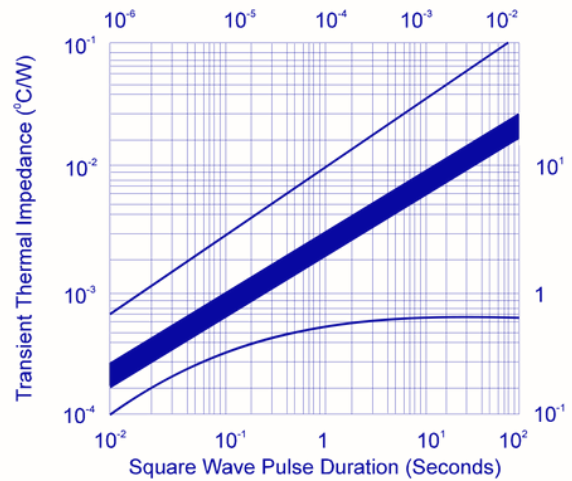
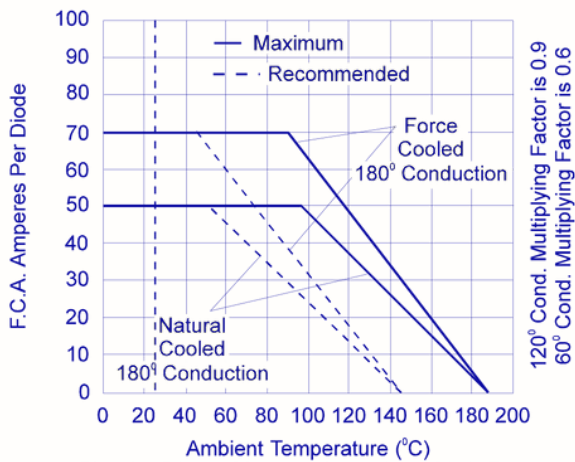

FIG. 6 diode mounted on heat sink
type K4 with $\theta_{HA NC} 0.95^\circ\text{C/W}$,
FC 0.30°C/W



POWER DIODE 70NC/RC

PACKAGE OUTLINE



WOL

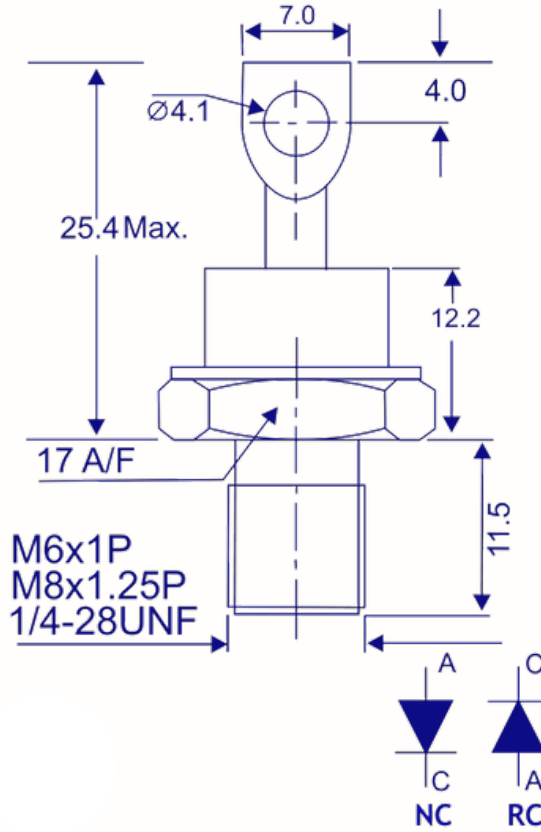

WL

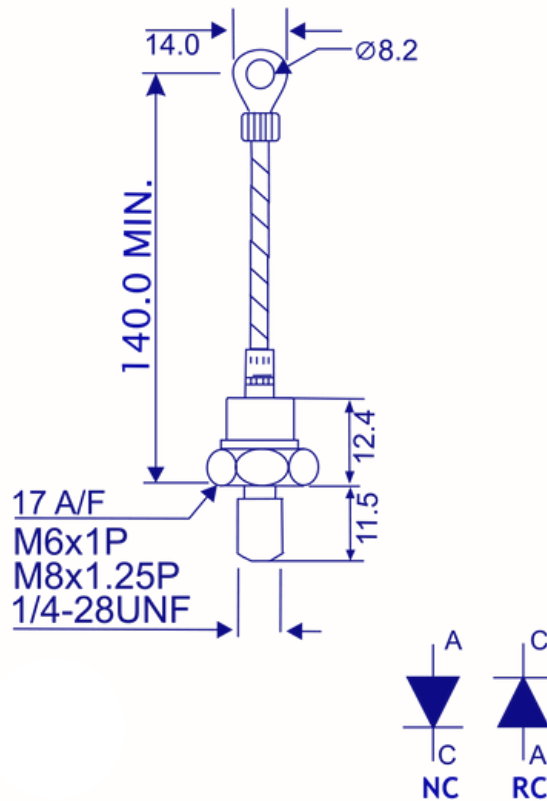

all dimensions in mm