

POWER DIODE

150ND/RD, 150NE/RE

FEATURES

- 👉 Available in Normal & Reverse Polarity
- 👉 All Diffused Series
- 👉 Industrial Grade
- 👉 Available in Avalanche Characteristic



STUD

FLAT

DO8

TYPICAL APPLICATIONS

- 👉 Power Supplies
- 👉 Machine Tool Controls
- 👉 Battery chargers
- 👉 Welders

POWER DIODE

150ND/RD, 150NE/RE



TECHNICAL DATA

DEVICE TYPE

V_{RRM}
(V)

V_{RSM}
(V)

150ND/RD40 150NE/RE40	400	500
150ND/RD120 150NE/RE120	1200	1300
150ND/RD160 150NE/RE160	1600	1700

SYMBOL	CONDITIONS	VALUES
$I_{F(AV)}$	Maximum average forward Current $T_c = 130^{\circ}C$	150A
V_{FM}	Maximum peak forward Voltage drop @ Rated $I_{F(Peak)}$	1.40 V
I_{FSM}	Maximum peak one cycle (non-rep.) surge current 10 msec	3570 A
I^2t	Max. I^2t rating (non-rep.) for 10 msec	64000 A ² Sec
I_{RRM}	Peak reverse current at $T_{vj} = 175^{\circ}C$	22 mA
V_0 R_0	$T_{vj} = \max$ $T_{vj} = \max$	0.85 V 1.10 m Ω
$R_{th(j-c)}$ $R_{th(c-h)}$ $R_{th(c-h)}$ T_{vj} T_{stg}	Maximum thermal resistance (Junction to case) Maximum thermal resistance (Case to heat sink)(ND,RD) Maximum thermal resistance (Case to heat sink)(NE,RE) Junction temperature Storage temperature	0.25 $^{\circ}C/W$ 0.10 $^{\circ}C/W$ 0.07 $^{\circ}C/W$ 200 $^{\circ}C$ 200 $^{\circ}C$
Mounting torque		10 Nm
Weight	Approx.	150 gms
Package Outline		D,E

POWER DIODE
150ND/RD,
150NE/RE

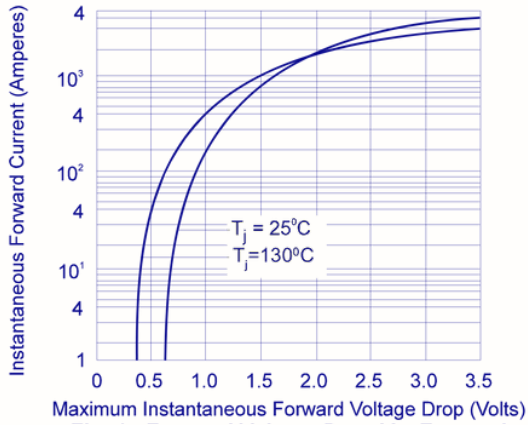

FIG. 1 forward voltage drop vs. forward current

FIG. 2 average forward current vs. case temperature

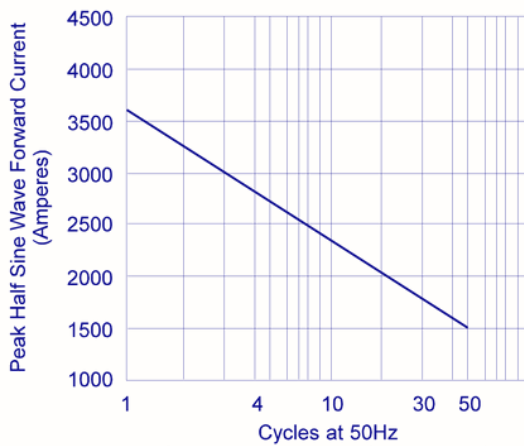
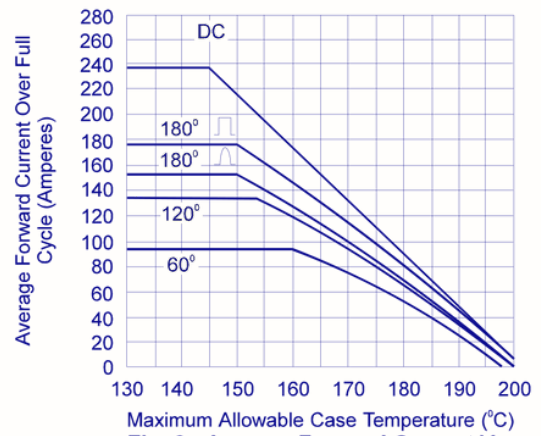

FIG. 3 maximum non recurrent surge current

POWER DIODE
150ND/RD,
150NE/RE

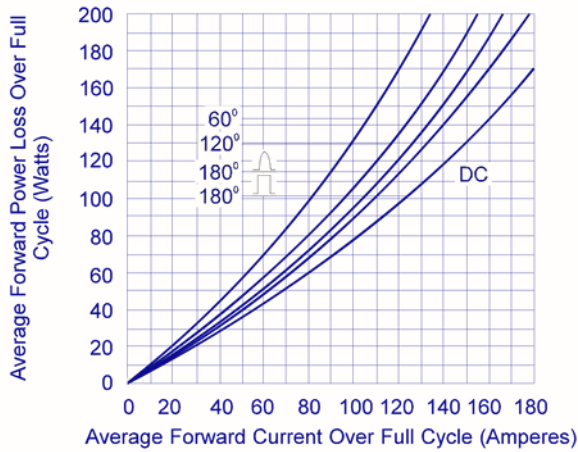

FIG. 4 average forward power loss vs. low level forward current

FIG. 5 transient thermal impedance

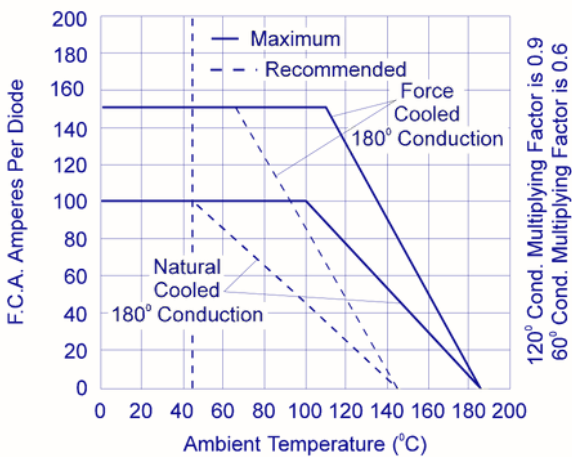
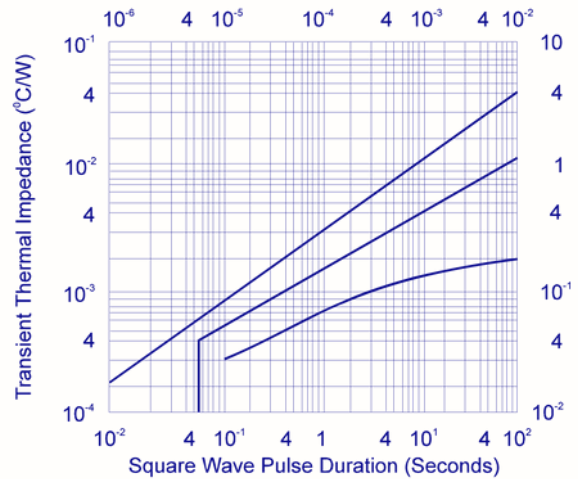

FIG. 6 diode 150nd/rd, 150ne/re on heat sink

type K4 with $\theta_{HA NC} 0.55^\circ C / W$,
FC $0.13^\circ C / W$

POWER DIODE
150ND/RD,
150NE/RE



PACKAGE OUTLINE

150ND/150RD

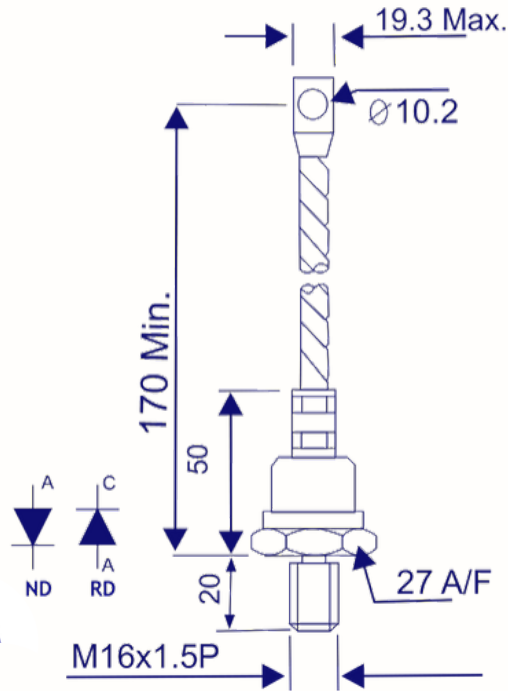

150NE/150RE

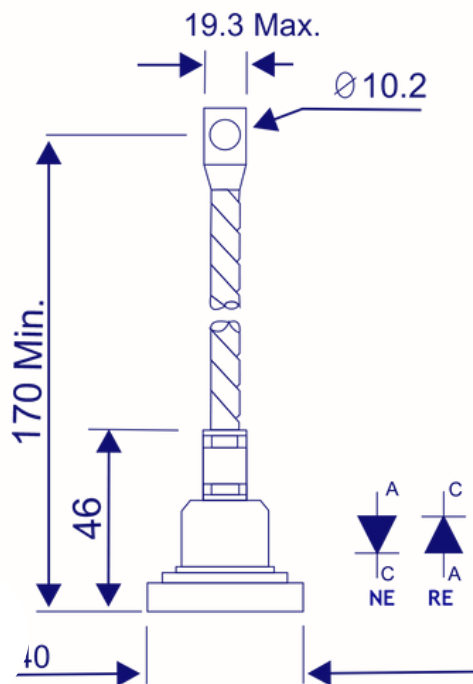

all dimensions in mm